

## P-Channel MOSFET

### BSP230 (KSP230)

#### ■ Features

- $V_{DS} (V) = -300V$
- $I_D = -0.21 A (V_{GS} = -10V)$
- $R_{DS(ON)} < 17 \Omega (V_{GS} = -10V)$
- High-speed switching

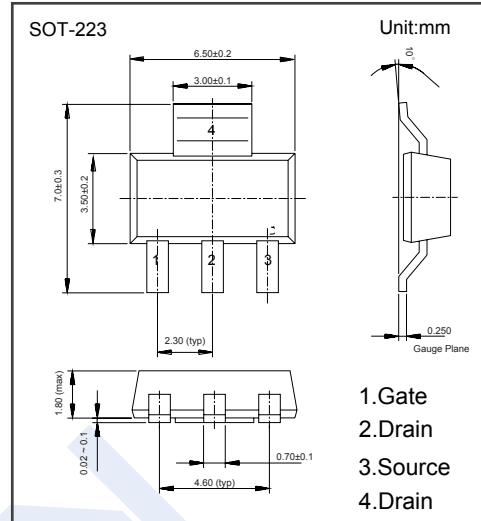
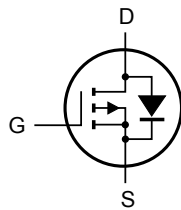

#### ■ Absolute Maximum Ratings $T_a = 25^\circ C$

Parameter	Symbol	Rating	Unit
Drain-Source Voltage	$V_{DS}$	-300	V
Gate-Source Voltage	$V_{GS}$	$\pm 20$	
Continuous Drain Current	$I_D$	-0.21	A
Pulsed Drain Current	$I_{DM}$	-0.75	
Power Dissipation	$P_D$	1.5	W
Thermal Resistance, Junction- to-Ambient	$R_{thJA}$	83.3	$^\circ C/W$
Junction Temperature	$T_J$	150	$^\circ C$
Junction Storage Temperature Range	$T_{stg}$	-65 to 150	

#### ■ Electrical Characteristics $T_a = 25^\circ C$

Parameter	Symbol	Test Conditions	Min	Typ	Max	Unit
Drain-Source Breakdown Voltage	$V_{DSS}$	$I_D = -250 \mu A, V_{GS} = 0V$	-300			V
Zero Gate Voltage Drain Current	$I_{DSS}$	$V_{DS} = -240V, V_{GS} = 0V$			-100	nA
Gate-Body leakage current	$I_{GSS}$	$V_{DS} = 0V, V_{GS} = \pm 20V$			$\pm 100$	nA
Gate Threshold Voltage	$V_{GS(th)}$	$V_{DS} = V_{GS}, I_D = -1mA$	-1.7		-2.55	V
Static Drain-Source On-Resistance	$R_{DS(on)}$	$V_{GS} = -10V, I_D = -170mA$			17	$\Omega$
Forward Transconductance	$g_{FS}$	$V_{DS} = -25V, I_D = -170mA$	100			ms
Input Capacitance	$C_{iss}$	$V_{GS} = 0V, V_{DS} = -25V, f = 1MHz$			90	pF
Output Capacitance	$C_{oss}$				30	
Reverse Transfer Capacitance	$C_{rss}$				15	
Turn-On DelayTime	$t_{d(on)}$	$V_{GS} = 0 \text{ to } -10V, V_{DS} = -50V, I_D = -250mA$			10	ns
Turn-Off DelayTime	$t_{d(off)}$				30	

## P-Channel MOSFET BSP230 (KSP230)

■ Typical Characteristics

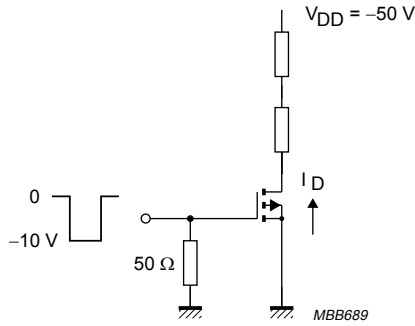

Fig.1 Switching time test circuit.

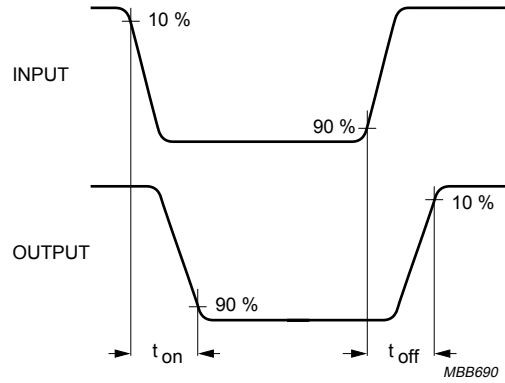

Fig.2 Input and output waveforms.

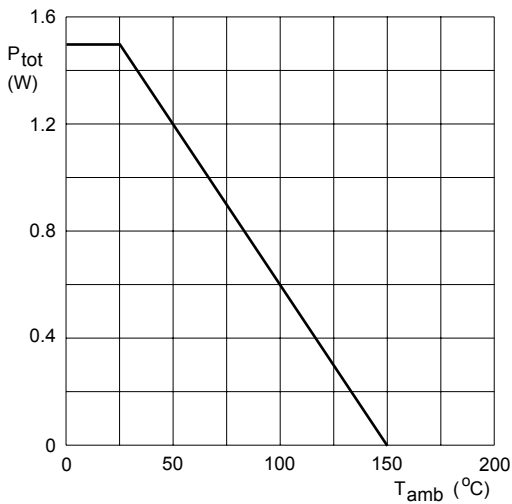

Fig.3 Power derating curve.

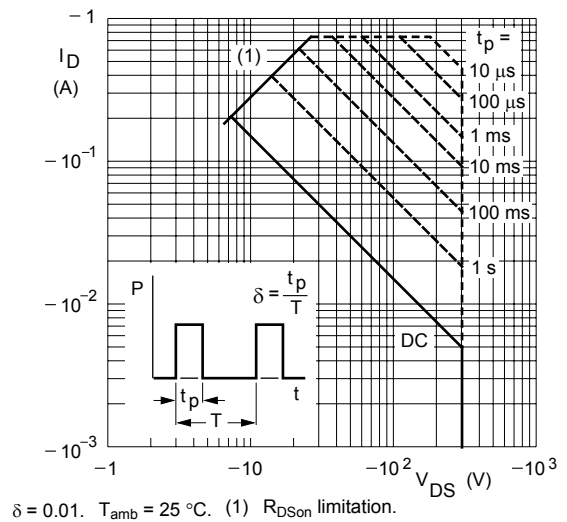

Fig.4 DC SOAR.

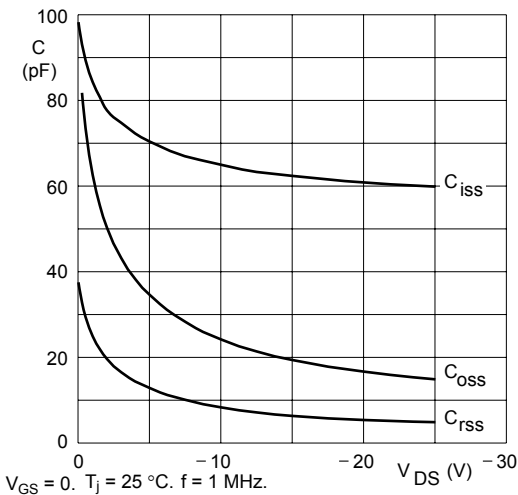

Fig.5 Capacitance as a function of drain source voltage; typical values.

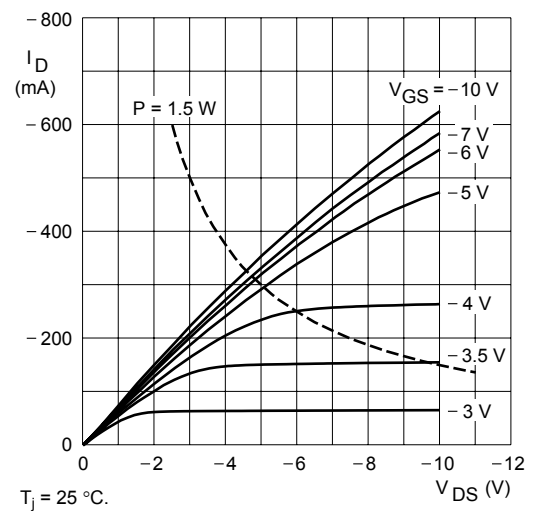
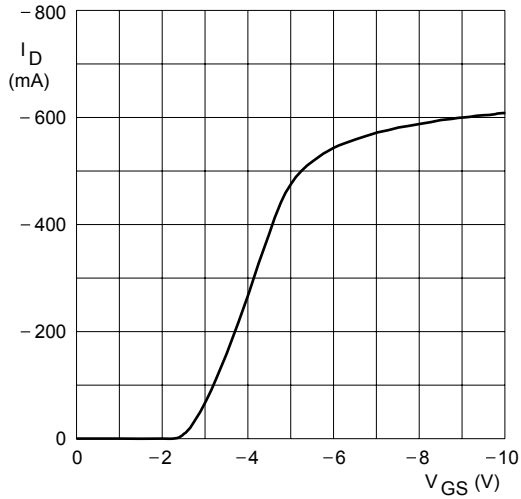

Fig.6 Typical output characteristics.

## P-Channel MOSFET BSP230 (KSP230)

■ Typical Characteristics



$V_{DS} = -25$  V.  $T_j = 25$  °C.

Fig.7 Typical transfer characteristics.

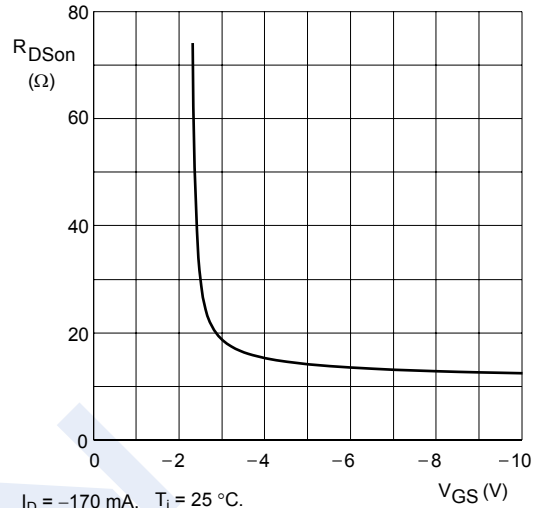

$I_D = -170$  mA.  $T_j = 25$  °C.

Fig.8 Drain-source on-state resistance as a function of gate-source voltage; typical values.

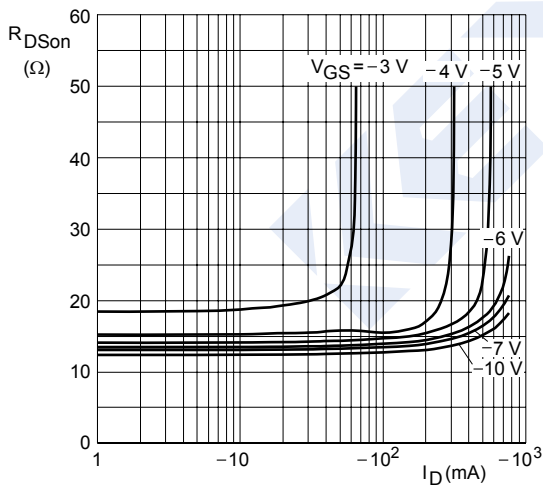

$T_j = 25$  °C.

Fig.9 Drain-source on-state resistance as a function of drain current; typical values.

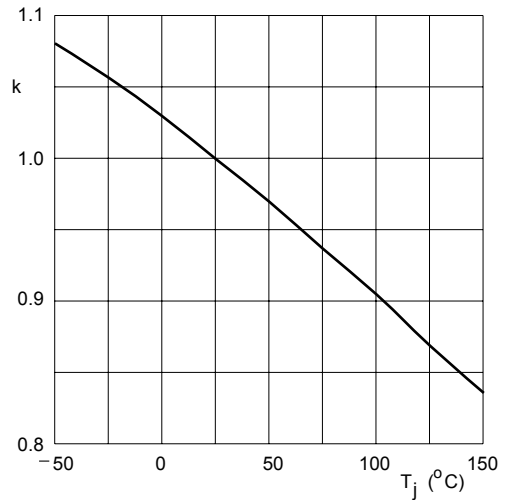

$$k = \frac{V_{GSth} \text{ at } T_j}{V_{GSth} \text{ at } 25^{\circ}\text{C}}$$

Typical  $V_{GSth}$  at  $I_D = -1$  mA;  $V_{DS} = V_{GS}$ .

Fig.10 Temperature coefficient of gate-source threshold voltage.

## P-Channel MOSFET BSP230 (KSP230)

■ Typical Characteristics

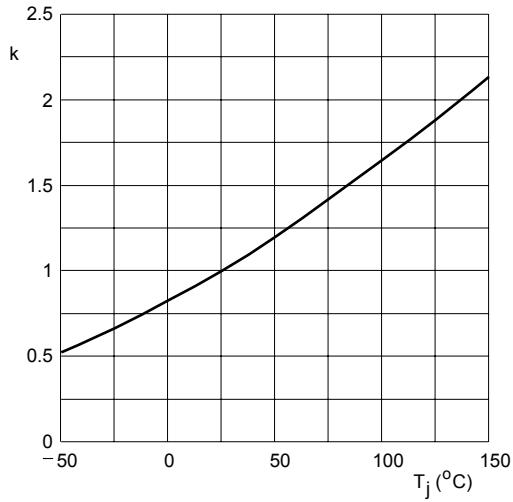

$$k = \frac{R_{DSon} \text{ at } T_j}{R_{DSon} \text{ at } 25^\circ\text{C}}$$

Typical  $R_{DSon}$  at  $I_D = -170\text{ mA}$ ;  $V_{GS} = -10\text{ V}$ .

Fig.11 Temperature coefficient of drain-source on-state resistance.

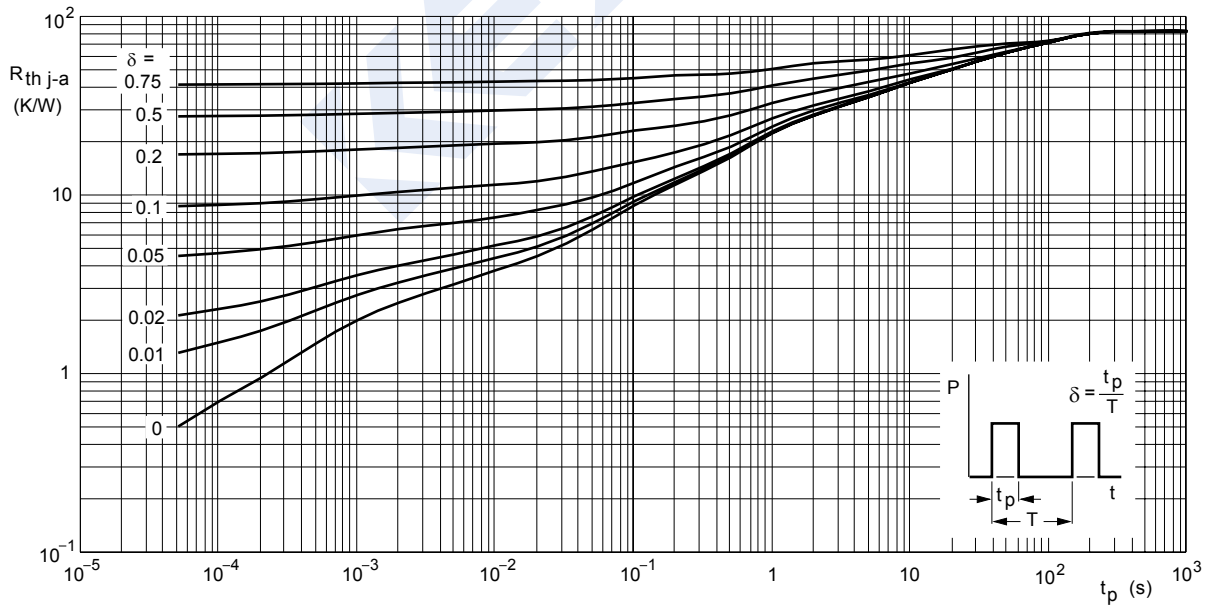

$T_{amb} = 25^\circ\text{C}$ .

Fig.12 Transient thermal resistance from junction to ambient as a function of pulse time; typical values.